

2"-3000# H.C. W/ STL. PLUG INSP. OPENING (2) PLC'S.

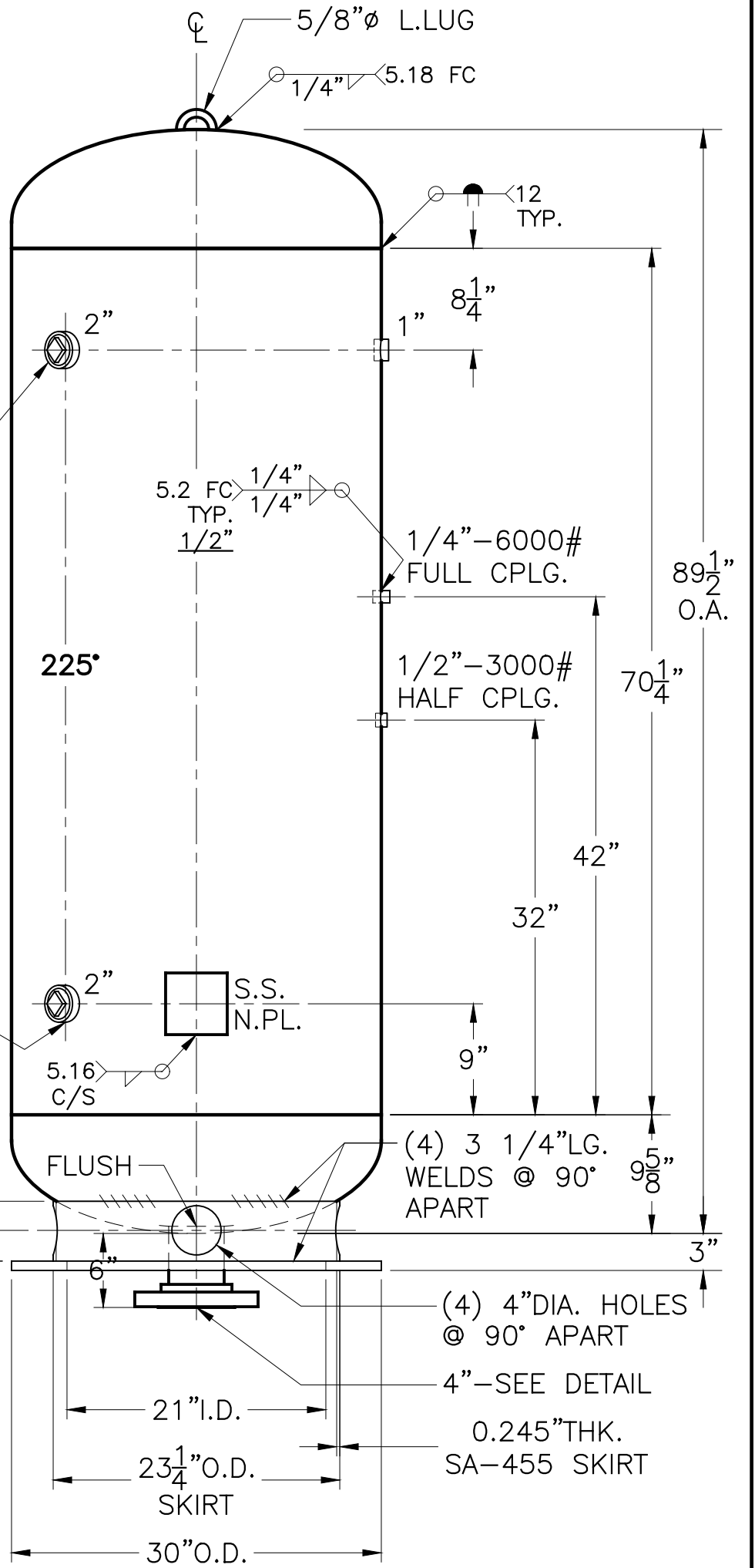

DATE	BY
2-6-15	JG
2-12-15	JG
2-13-15	JG

SHELL / HEADS	
M.A.W.P.	550 PSIG. @ 400 °F
M.D.M.T.	-20 °F @ 550 PSIG.
ASME SECTION VIII	DIV. 1, 2013
X-RAY	RT-4 SPOT L.S. ONLY
GALLONS	240 WT. 1575 LBS.
SERIAL NO.	N.B.
.500" SA-516-70 2:1 S.E. (.472" MIN.) BEVEL	
HOT FORMING NOT REQUIRED	
UCS 79(D)	
.500" SA-455	

NOTE: 1) PRE-HEAT BEFORE WELDING TO 150°-200°
2) HYDRO @ 715 PSIG. MIN.

AH-901-B		REV. 2-13-15
DATE: 2-6-15		
FOR: VERT. AIR TANK		
SURFACE AREA = 62.3 SQ. FT.		
UW-21(b)		
INSIDE: UNPAINTED		
OUTSIDE: PRIME		
BY: E.S. / B.C. SCALE: 1"=12"		
ROY E. HANSON JR. MFG.		
1600 E. WASHINGTON BLVD. LOS ANGELES, CA 90021		

