

- NOTE: 1) SEAL ALL OPENINGS TO KEEP CEMENT MOIST TO PREVENT CRACKING.  
 2) HYDRO @ 240 PSIG.  
 3) EXTEND ALL CPLGS. 5/8" INSIDE.  
 4) 4-22-04 PROOF TEST.

- (4) 3"x 3"x 3/8" THK. x 23 3/8" LG. ANGLE LEGS  
 (4) 4"x 4"x 3/8" THK. PAD W/ 3/4" Ø HOLE FOR 1/2" Ø x 6" LG. BOLTS GRADE 5 OR BETTER

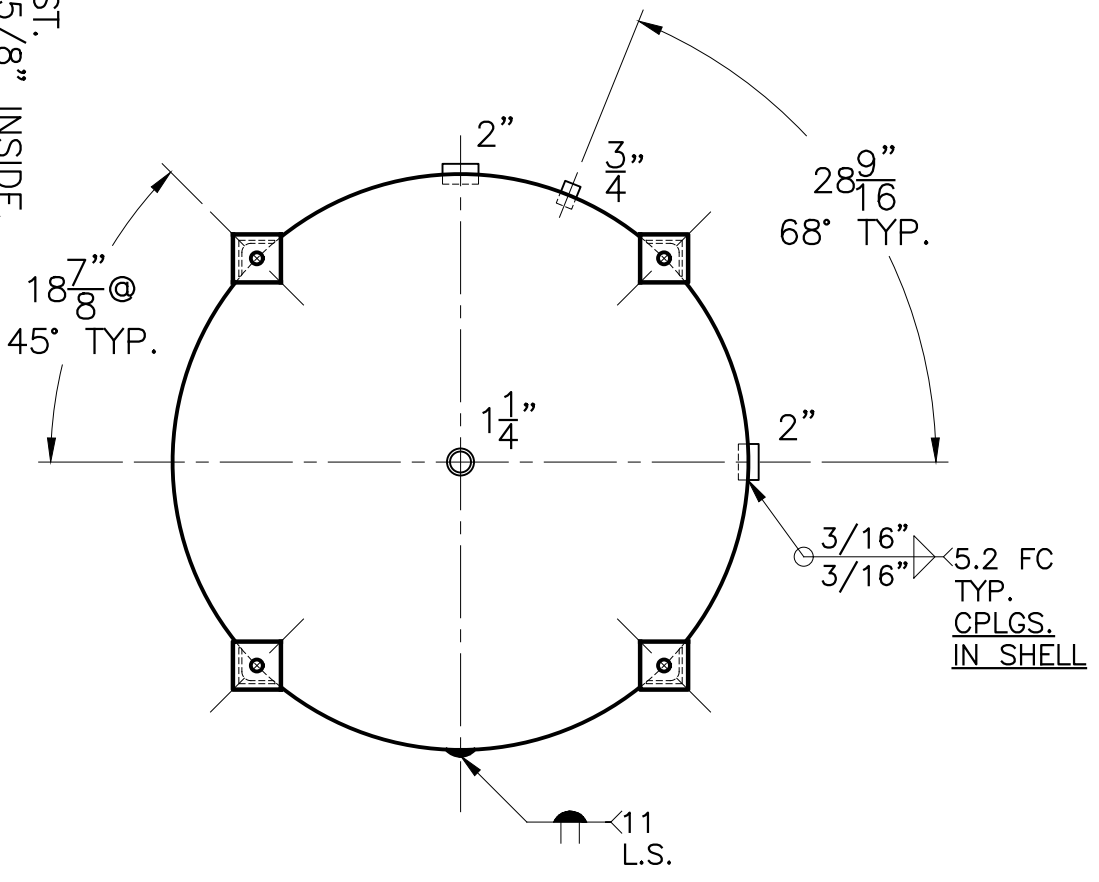

|                                |               |
|--------------------------------|---------------|
| SHELL / HEADS                  |               |
| .200" SA-455                   |               |
| M.A.W.P. 160 PSIG. @ 210 °F    |               |
| ASME SECTION IV 2004 ADD. 2006 |               |
| X-RAY: RT-NO / H.L.W.          |               |
| GALLONS: 585                   | WT. 1695 LBS. |
| SERIAL NO.                     |               |
| N.B.                           |               |
| .245" SA-455 2:1 S.E.          |               |
| JOGGLE - .208 OFFSET           |               |

|  |                  |              |
|--|------------------|--------------|
| FOR: HANSON STANDARD VERT. HOT WATER TANK.   | CS-48-585-V      | REV. 1-22-07 |
| 94.5 SQ. FT. SURFACE AREA. THIS TANK IS SHIPPED WITH ALL OPENINGS SEALED. THE CEMENT LINING MUST BE KEPT MOIST BEFORE, DURING, AND AFTER INSTALLATION TO PREVENT CRACKING OF THE CEMENT. | DATE: 12-9-97    |              |
| INSIDE: CEMENT LINED   |                  |              |
| OUTSIDE: PRIME   |                  |              |
| (556) LEG-ZONE 4-15 KM.  |                  |              |
| CAD-"B" UNDER "STD"-SERIES   |                  |              |
| BY: J.G.   | SCALE: 3/4" = 1' |              |
| <b>ROY E. HANSON JR. MFG.</b>  |                  |              |
| 1600 E. WASHINGTON BLVD.<br>LOS ANGELES, CA 90021  |                  |              |