

(4) 4"x 4"x 1/4"THK. x 23 1/4"LG. ANGLE LEGS  
 (4) 6"x 6"x 1/2"THK. PAD W/ 7/8"Ø HOLE FOR 5/8"Ø x 8"LG. BOLTS GRADE 5 OR BETTER 6" EMBEDMENT

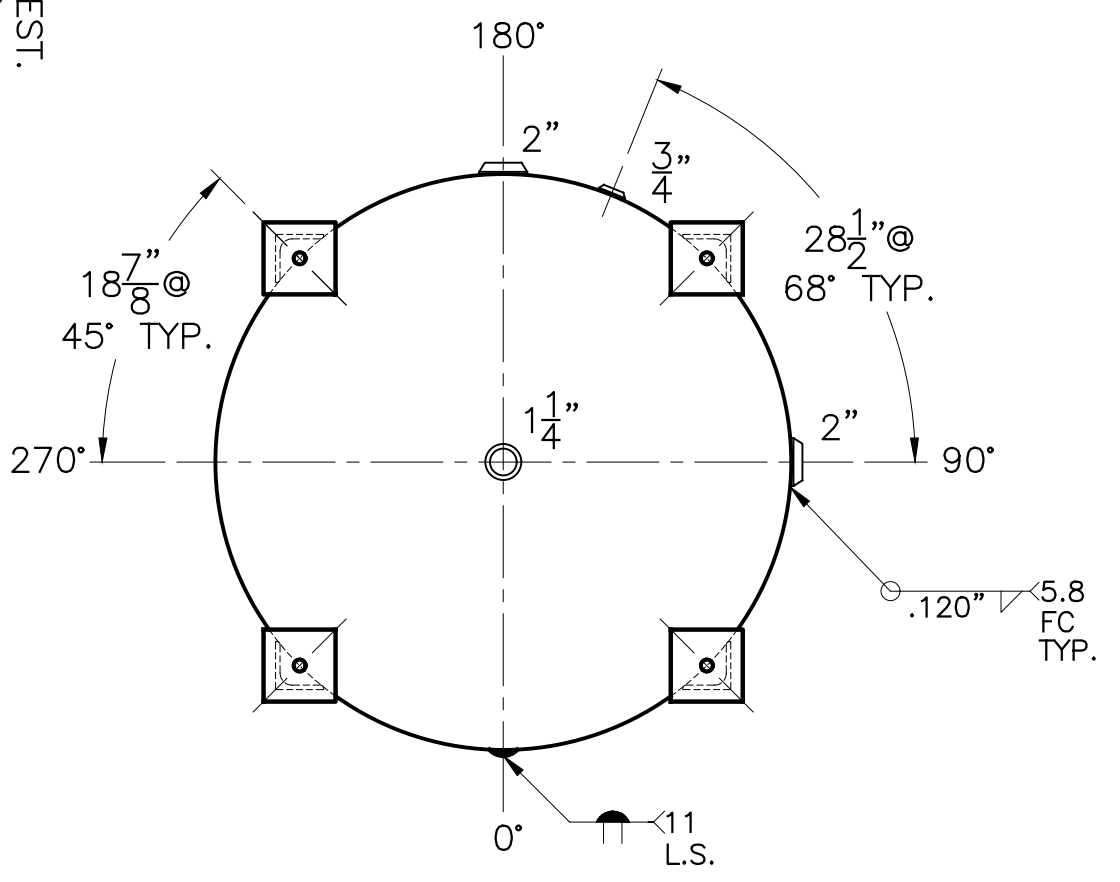

NOTE: 1) HYDRO @ 240 PSIG.  
 2) 4-22-04 PROOF TEST.

SHELL / HEADS		.245" SA-455 2:1 S.E.	
JOGGLE			
M.A.W.P. 160 PSIG. @ 180 °F			
ASME SECTION IV 2010 ADD. 2010			
X-RAY: RT-NO / H.L.W.			
GALLONS: 712 WT. 1162 LBS.			
SERIAL NO.			
N.B.			
ES-48-712-V		REV. 7-14-11	
FOR: HANSON STANDARD		DATE: 3-10-03	
VERT. WATER TANK.			
SURFACE AREA = 113 SQ. FT.			
INSIDE: EPOXY LINED			
OUTSIDE: PRIME			
LEG-ZONE 4-15 KM.			
CAD-"B" UNDER "STD"-SERIES			
BY: J.G.		SCALE: 3/4"=12"	
<b>ROY E. HANSON JR. MFG.</b>			
1600 E. WASHINGTON BLVD.			
LOS ANGELES, CA 90021			