

- 4) SHELL: 4-22-04 PROOF TEST.
- 3) EXTEND ALL CPLGS. 5/8" INSIDE.
- 2) HYDRO @ 240 PSIG. MIN.

NOTE: 1) SEAL ALL OPENINGS TO KEEP CEMENT MOIST TO PREVENT CRACKING.

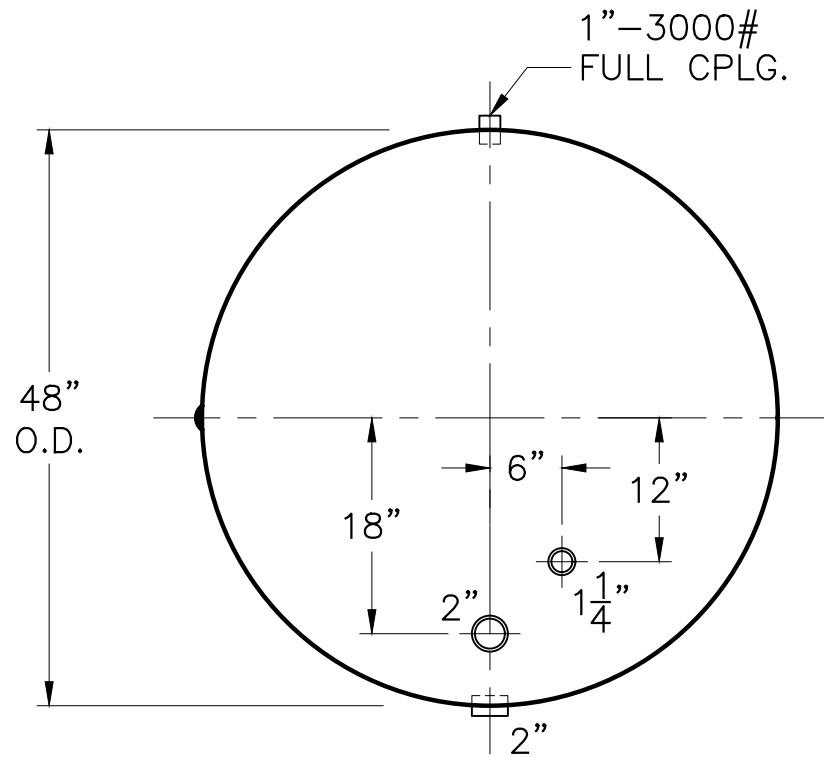

VIEW W/O SUPPORTS

SHELL / HEADS	.250" SA-455 2:1 S.E. (.230" MIN.) JOGGLE	CS-48-900-H	REV. 12-21-15
	.200" SA-455		DATE: 10-3-89
M.A.W.P. 160 PSIG. @ 210 °F		FOR: HANSON STANDARD	
ASME. SECTION IV 2015		HORIZ. HOT WATER TANK	
X-RAY: RT-NO / H.L.W.		136.7 SQ. FT. SURFACE AREA. THIS TANK IS SHIPPED WITH ALL OPENINGS SEALED. THE CEMENT LINING MUST BE KEPT MOIST BEFORE, DURING, AND AFTER INSTALLATION TO PREVENT CRACKING OF THE CEMENT.	
GALLONS: 900 WT. 2333 LBS.		INSIDE: CEMENT LINED (851)	
SERIAL NO.		OUTSIDE: PRIME	
N.B.		CAD-"B" UNDER "STD"-SERIES	
		BY: E.S. SCALE: 3/4"=12"	
		ROY E. HANSON JR. MFG.	
		LOS ANGELES, CA 90021	