

(3) 2 1/2" x 2 1/2" x 3/16" THK. x 16 1/16" LG. ANGLE LEGS

(3) 4" x 4" x 1/4" THK. PAD W/ 3/4" Ø HOLE FOR 1/2" Ø x 8" LG. BOLTS GRADE 5 OR BETTER 6" EMBEDMENT

3" R W/ LONG PILOT
(4) PLC'S
SEE NOTE: 2

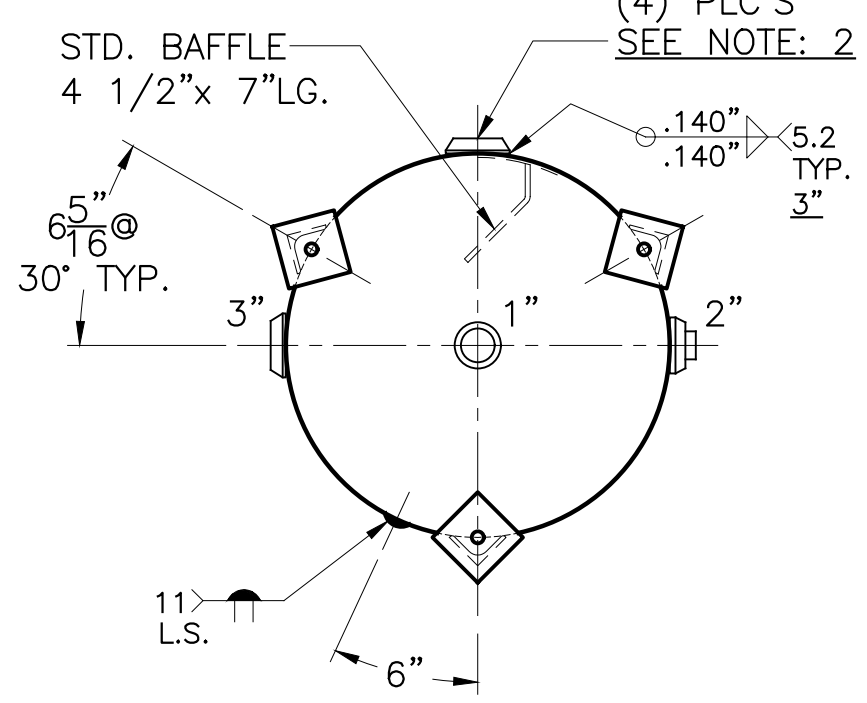

NOTE: 1) 2) 3" R W/ LONG PILOT - MACHINE TO 4 5/16" O.D. HYDRO @ 195 PSIG. MIN.

SHELL / HEADS	
JOGGLE	.164" SA-414-G 2:1 S.E.
M.A.W.P.	150 PSIG. @ 300 °F
M.D.M.T.	0 °F @ 150 PSIG.
ASME SECTION VIII	DIV. 1, 2007 ADD 2009
X-RAY:	RT-NO
GALLONS:	115 WT. 242 LBS.
SERIAL NO.	
N.B.	

WM-939-B	REV. DATE: 4-16-10
FOR:	VERT. HOT WATER (BUFFER) TANK
	SURFACE AREA = 35.9 SQ. FT.
INSIDE:	UNPAINTED
OUTSIDE:	SHOP PRIME & R-16
	LEG-ZONE 4-15 KM.
BY:	E.S. / C.J. SCALE: 1"=12"
ROY E. HANSON JR. MFG.	
1600 E. WASHINGTON BLVD. LOS ANGELES, CA 90021	