

(4) 2 1/2" x 2 1/2" x 3/16" THK.  
x 24 1/8" LG. ANGLE LEGS  
304 S.S.  
(4) 4" x 4" x 1/4" THK.  
304 S.S. PAD W/ 3/4"  $\phi$  HOLE

NOTE: 1) HYDRO @ 195 PSIG. MIN.  
2) ALL FNPT'S SA-182-304 S.S.  
3) CRN ALBERTA V6148.2

SHELL / HEADS	
JOGGLE	.1875" SA-240-304 2:1 S.E.
	.1875" SA-240-304
	LEG-ZONE 3-15 KM.
M.A.W.P.	150 PSIG. @ 200 °F
M.D.M.T.	-60 °F @ 150 PSIG.
ASME SECTION VIII	DIV. 1, 2017
X-RAY:	RT-NO
GALLONS:	200 WT. 463 LBS.
SERIAL NO.	
N.B.	

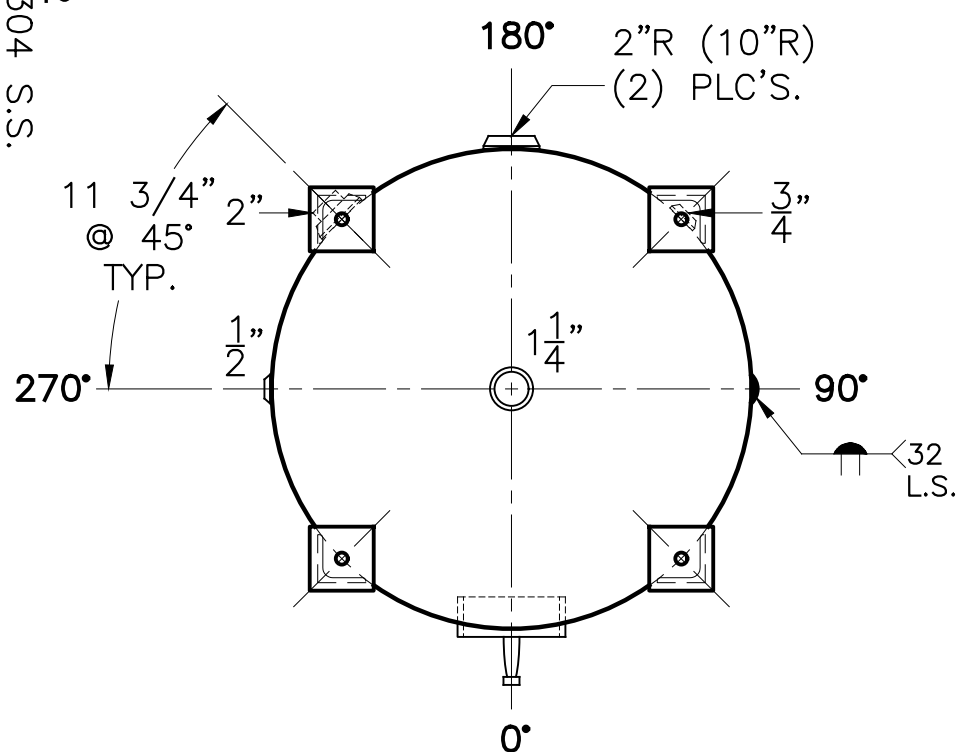

WN-354-B  
REV: 10-4-19  
DATE: 10-3-11

FOR: VERT. WATER TANK  
CRACKING OF STAINLESS STEEL  
WATER TANKS, HOWEVER CAUSED,  
IS NOT A RESPONSIBILITY OF  
HANSON AND IS EXCLUDED FROM  
HANSON LIMITED WARRANTY.  
INSIDE: PASSIVATE  
OUTSIDE: BEAD BLAST & PASSIVATE  
BY: J.A. / B.C. SCALE: 1" = 12"  
**ROY E. HANSON JR. MFG.**  
LOS ANGELES, CA 90021