

JOB No. \_\_\_\_\_  
DATE: \_\_\_\_\_

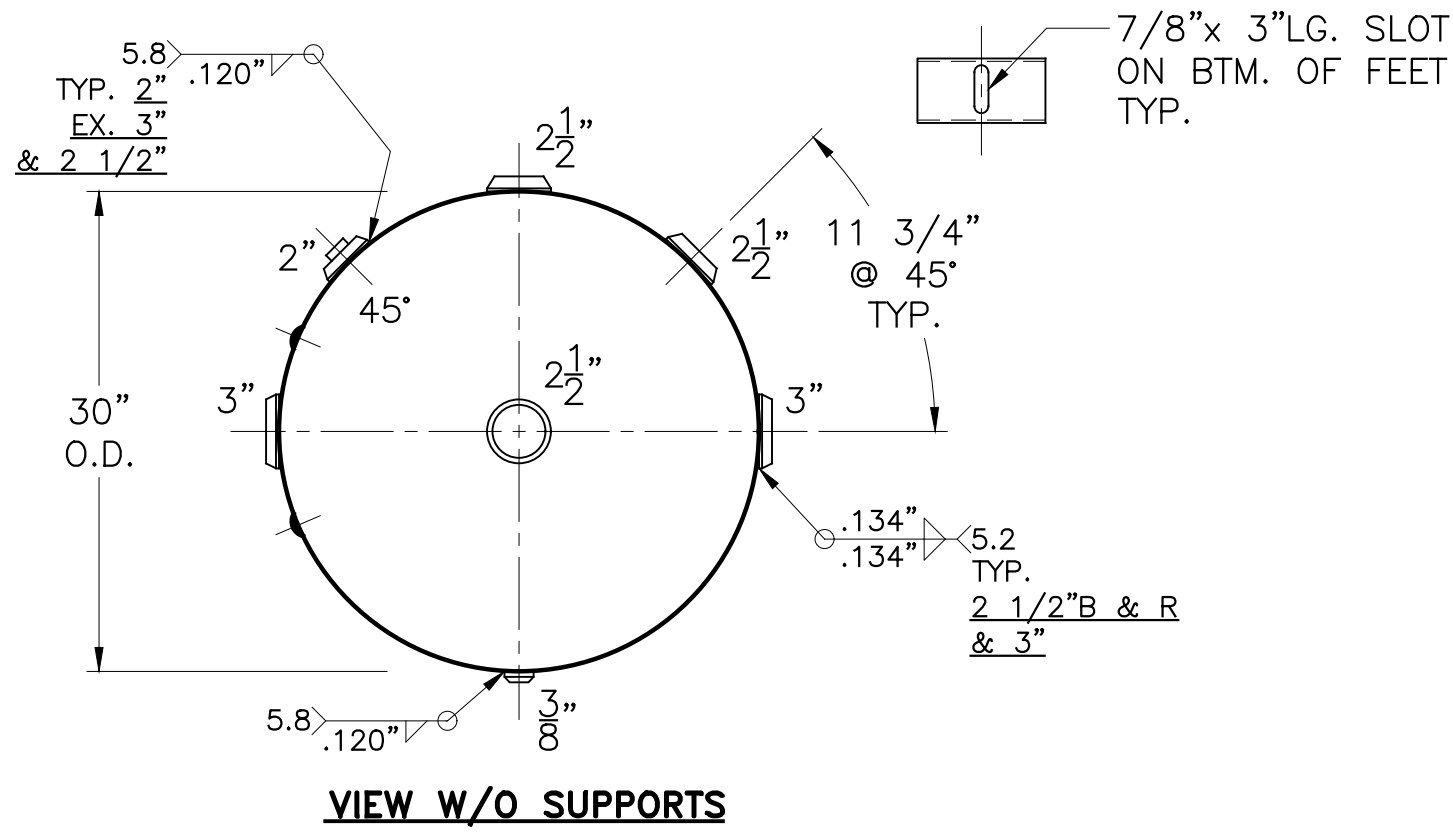
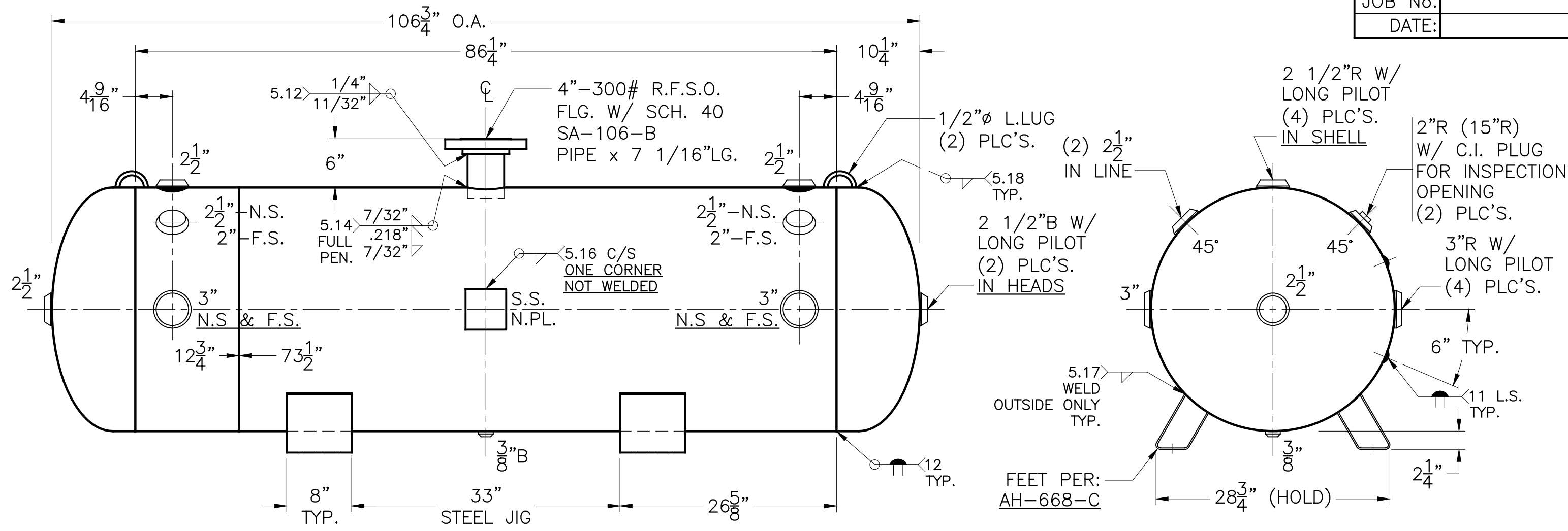

- 4) INSTALL SQUARE HEAD PLUGS WITH TEFLON TAPE, AIR TIGHT, IN ALL FNPT'S., CAP 4" WITH PLASTIC CAP.
- 3) POST WELD STRESS RELIEVE.
- 2) HYDRO TEST AFTER POST WELD HEAT TREAT.
- NOTE: 1) HYDRO @ 260 PSIG. MIN.

SHELL / HEADS	.252" SA-455 2:1 S.E.	AH-626-B	REV. 1-8-20
	JOGGLE		DATE: 6-4-09
SHELL / HEADS	.218" SA-455	FOR:	
		HORIZ. AIR TANK	
M.A.W.P. 200 PSIG. @ 400 °F		SURFACE AREA = 72.4 SQ. FT.	
M.D.M.T. 0 °F @ 200 PSIG.		UW-21(b)	
ASME SECTION VIII DIV. 1, 2019		INSIDE: DEHYDRATE, S. BLAST AND VACUUM CLEAN	
X-RAY: RT-NO		OUTSIDE: S. BLAST & PRIME	
GALLONS: 300 WT. 810 LBS.		BY: J.G./B.C. SCALE: 1"=12"	
SERIAL NO.		<b>ROY E. HANSON JR. MFG.</b>	
N.B.		LOS ANGELES, CA 90021	